



REVENT 726 / G /

Single Rack Gas Oven

Max pan size:
1 single rack (18"x26" or 20"x30")
Available in gas/oil heated models

FEATURES

Baking quality

- > Bakes everything without adjustments.
- > The TCC (Total Convection Control) system ensuring:
 - Even bake
 - Perfectly even coloured products
 - Minimized weight loss
 - Maximized bread volume
- > The HVS (High Volume Steam) system ensuring:
 - Excellent texture
 - Excellent crust

Total Cost of Ownership

- > Perfect bake without rejects.
- > Industry leading availability and output for 24/7 production.
- > Most flexible choice for a diversified bakery assortment.
- > Simple handling with self-instructive GIAC control panel.
- > Bakes up to four different products at once with our multiple-alarm system.
- > Renowned durability with the longest life expectancy on the market.
- > World leading energy efficiency, verified through accredited institute, through:
 - Revent cross-line heat exchanger
 - Energy save mode.
- > Minimized service cost.
- > Fast assembly through Revent's unique wedge system. Quick and easy installation. Baking within a few hours.

Options

- > Rack lifts for most types of racks including A-lift, B-lift, Baxter lift, C-lift, D-lift, Lucks lift
- > Platform
- > Heavy Duty Steam system
- > Type 1 canopy
- > GIAC extended PC software
- > Left hinged door.
- > Core temp sensor kit. (Requires F-lift or platform)
- > Prison package
- > USDA package (Upgrade of steel to A304)



In Bread We Trust

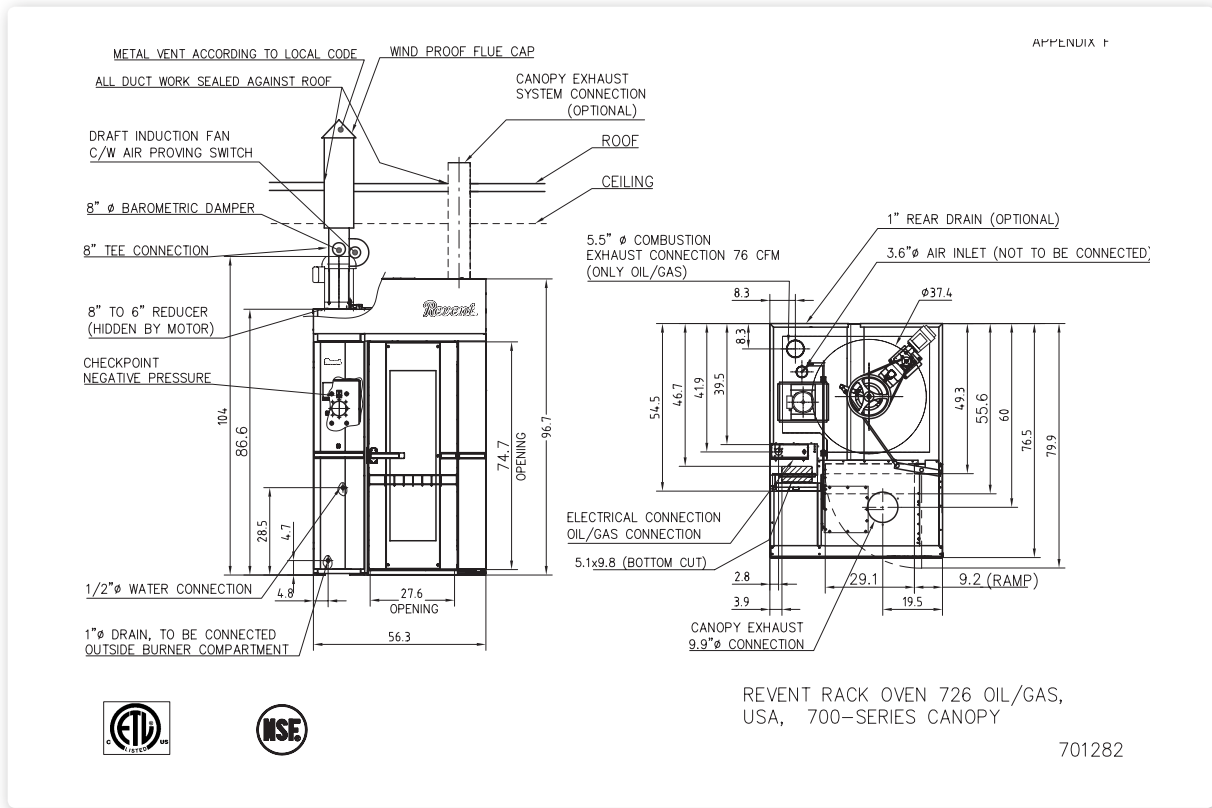

Specifications

Maximum Heat Capacity	170,000 btuh
Temperature range	95-572°F
Total shipping weight	2425 lbs*
Minimum intake opening	
- without skid	39"x56"
- with skid	41.5"x62"
	(standard 2 section + steam box delivery)
Minimum intake opening	55.2"x57.1" (optional one-piece shipment without skid)
Minimum section tilt up height and recommended service height:	106"
Swing diameter	37.4"
Max load of racklift and platform	441 lbs
Steam Generation	1.85 gals/20 sec at 482°F

***Final shipping**
Weights will depend on the final order specifications. Continuous product development is a Revent policy. Therefore, we reserve the right to change specifications and/or design without prior notice. Pictures or drawings may include product options.

Utility requirements

Electrical	
Standard	3PH208-220V+N 13A
Optional	3PH440-480V 6A +1PH/120V/60 Hz 15A
	Contact factory for other power options
Gas	
Natural Gas and Liquid propane	170,000 btuh @ 7-14" w.c and 1/2" drop to 1/2" NPT
Water and Drain	
Water Supply	1/2"NPT ø 60-65 PSI cold
Drain	1" NPT, optional connection to rear
Water quality	pH 7-8.5 Hardness 4-7 gr/gals. Acceptable range for chlo ride concentration 0-50 ppm
Ventilation	
<i>Combustion flue</i>	Directly from top of oven connect 5" reducer to 8" tee and install barometric damper (included with oven). Above this damper install draft inducer (included with oven) into 8 "single wall combustion exhaust pipe. Run 8" type "B" vent from top of draft inducer and continue on through the roof.

The draft inducing fan included with the oven is not designed for more than (2) 45 degree elbows. Draft should be -0.12 to -0.24" w.c. Contact factory for assistance if installation site does requires venting with additional bends or horizontal runs.

Over Pressure Duct
Through door to canopy

Oven Damper Exhaust
Through door to canopy

Canopy vent
10" connection. Min 883 cfm required. Customer to provide duct and ventilator fan per local code.

Installation requirements

The oven must be installed on a levelled non-combustible surface. The oven may be installed flush against a wall. Only the front and top need to be left open for access. The space on top of the oven must be well ventilated and the temperature must not exceed 120°F. This is to avoid damage to electric components.

Revent sales representative:



Revent Incorporated
100 Ethel Road West, Piscataway, New Jersey 08854
Phone (732) 777-9433, Fax (732) 777-1187
Toll Free 800-822-9642
E-mail info@revent.com, www.revent.com